

---

# Integrating Nutrition Into HIV/AIDS Care and Support Programs

---



# Acknowledgements

The Ministry of Health would like to very sincerely thank the University Research Co., LLC (URC) Nulife Program, with support from the United States Agency for International Development (USAID) for the technical and financial support which was so essential for the development, printing and dissemination of these Community-Level job aids on Comprehensive Nutrition Care and Support for People Living with HIV.

Sincere gratitude is extended to all development partners who participated in the multiple technical working groups and review committees for their contributions from the time of their inception through the final stages. Non-governmental organisations including Food and Nutrition Technical Assistance (FANTA), the International Baby Food Action Network (IBFAN), the Elizabeth Glazier Pediatric AIDS Foundation (EGPAF), Protecting Families Against HIV/AIDS (PREFA), Catholic Relief Services (CRS), Save the Children in Uganda (SCIUG) and many others invested substantial time and resources. The process has been very labour intensive and the development would not have been possible if it were not for the untiring efforts and commitment of these organisations and individuals.

Special recognition is made to the Nutrition Unit and the Division of Health Promotion and Education of the Ministry of Health, and also members of the Maternal and Child Health Cluster, Senior Management Committee, Health Policy Advisory Committee and Top Management Committee of the Ministry of Health for their technical input in reviewing and refining this set of job aids.

**Financial support was provided by USAID, Cooperative Agreement number 617-A-00-08-00006-00.  
The views expressed in this document do not necessarily reflect those of USAID.**

**NuLife Project supports the Uganda Ministry of Health and partners to integrate Nutrition in HIV/AIDS Care and Treatment Programs.**

**NuLife is implemented by University Research Co., LLC, (URC) in collaboration with Save the Children U.S.A and ACDI/VOCA.**

# Your Role as a Community Volunteer

## Nutrition Care and Support for Children

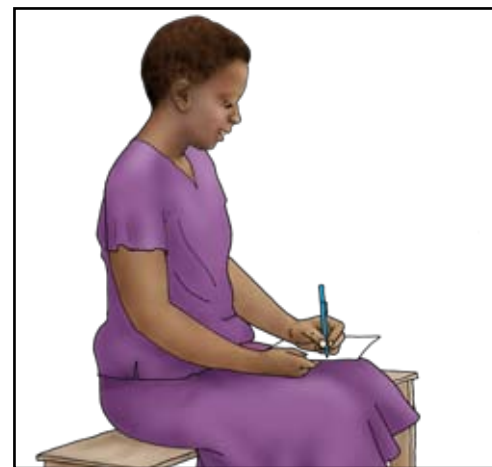

**Creating Awareness/  
Counselling**



**Assessing**



**Referral/ Reporting**



**Follow-up**

# Your Role as a Community Volunteer

## Nutrition Care and Support for Adults

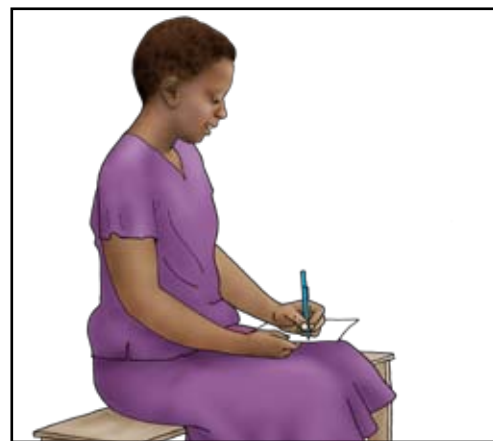

Creating Awareness/  
Counselling



Assessing



Referral/ Reporting



Follow-up

# Using a MUAC Tape for Nutritional Assessment

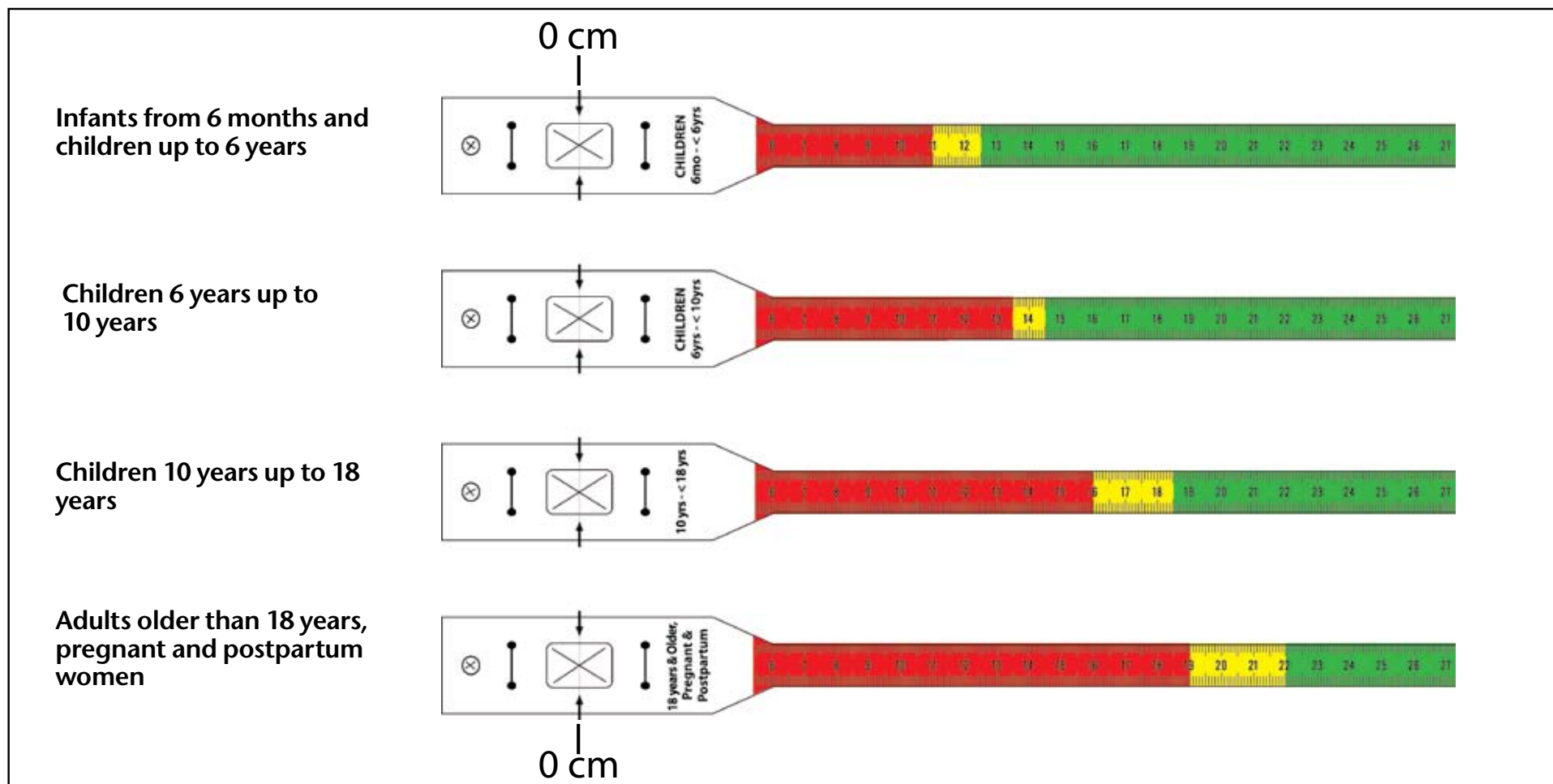

MUAC stands for "mid upper arm circumference". A MUAC tape is a simple tool to measure a person's nutrition status.

There are 4 different tapes, for 4 age groups.

Each MUAC tape has the same color coding:



severe acute malnutrition (SAM)



moderate acute malnutrition (MAM)



mild or no malnutrition

# Target Groups for MUAC Measurement

Infants from 6 months  
& Children less than  
18 years



Adolescents & Adults  
(18 years and above)



Pregnant & Postpartum  
Women with infants less than  
6months old



# Steps to accurately use a MUAC tape

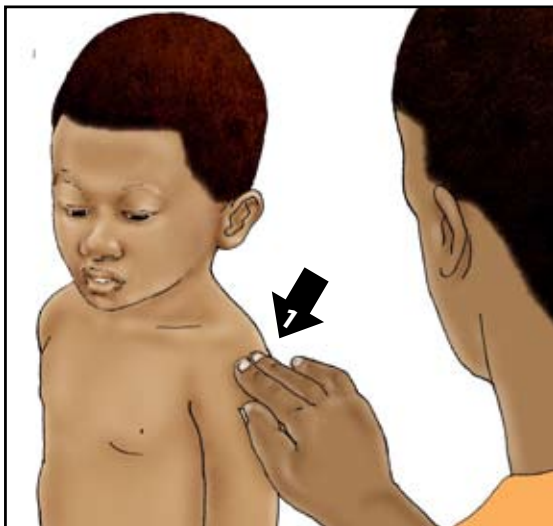

1. Bend left arm at angle of 90 degrees

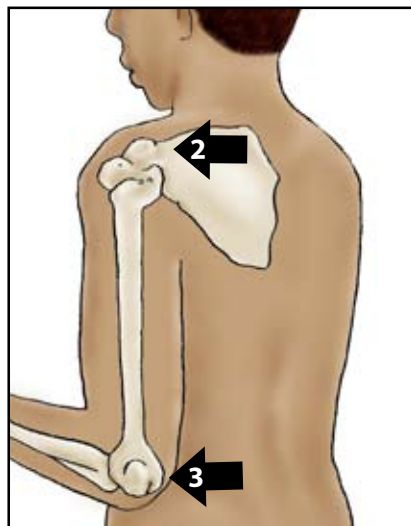

2. Locate tip of shoulder  
3. Locate tip of elbow

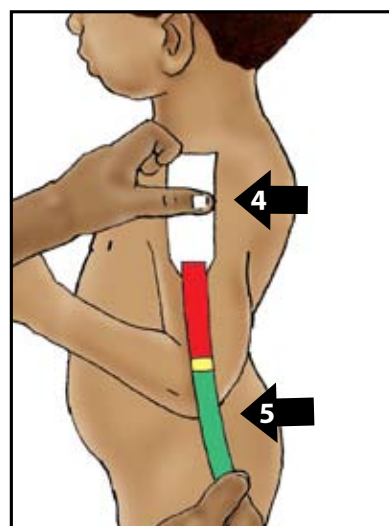

4. Place tape at 0 cm at tip of shoulder  
5. Pull tape past tip of bent elbow and read length of upper arm

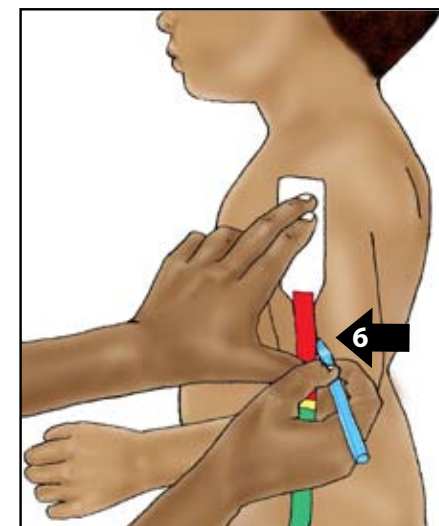

6. Determine mid-point by:  
- Folding the tape in half from "0" to the measured length OR  
- Calculating  
7. Mark mid-point using finger or pen

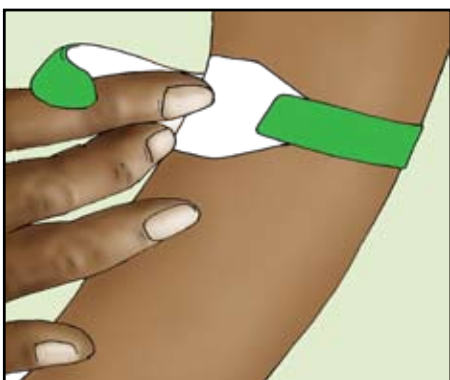

8. Straighten arm and place MUAC tape around the mid-point  
9. Place MUAC tape through window of tape, and correct the tape tension

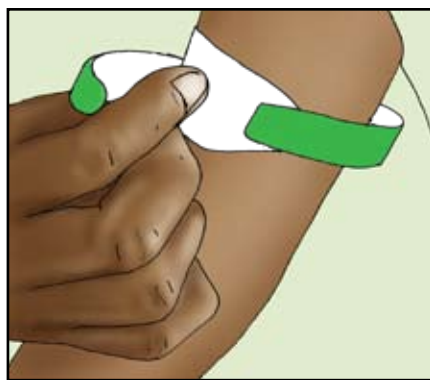

**Tape too Loose**



**Tape too tight**

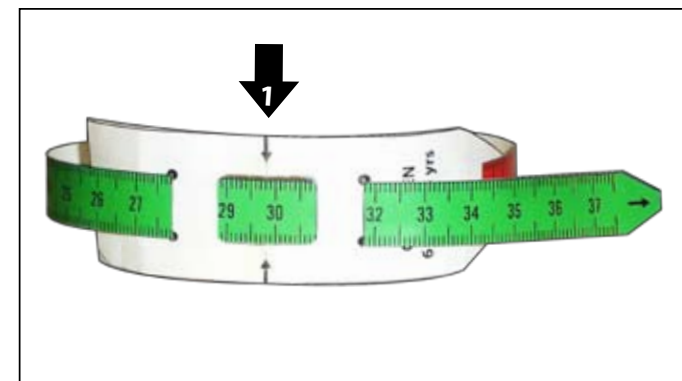

10. Read the cm measurement in the window at arrow  
11. Record measurement and the color zone observed

# How to Check for Swelling of Both Feet

Swelling of the feet caused by malnutrition occurs on both feet:

- it starts on both feet and can spread to the rest of the body
- when the feet are firmly pressed with the thumbs for 3 seconds, and then removed, pits are left in the skin as shown below

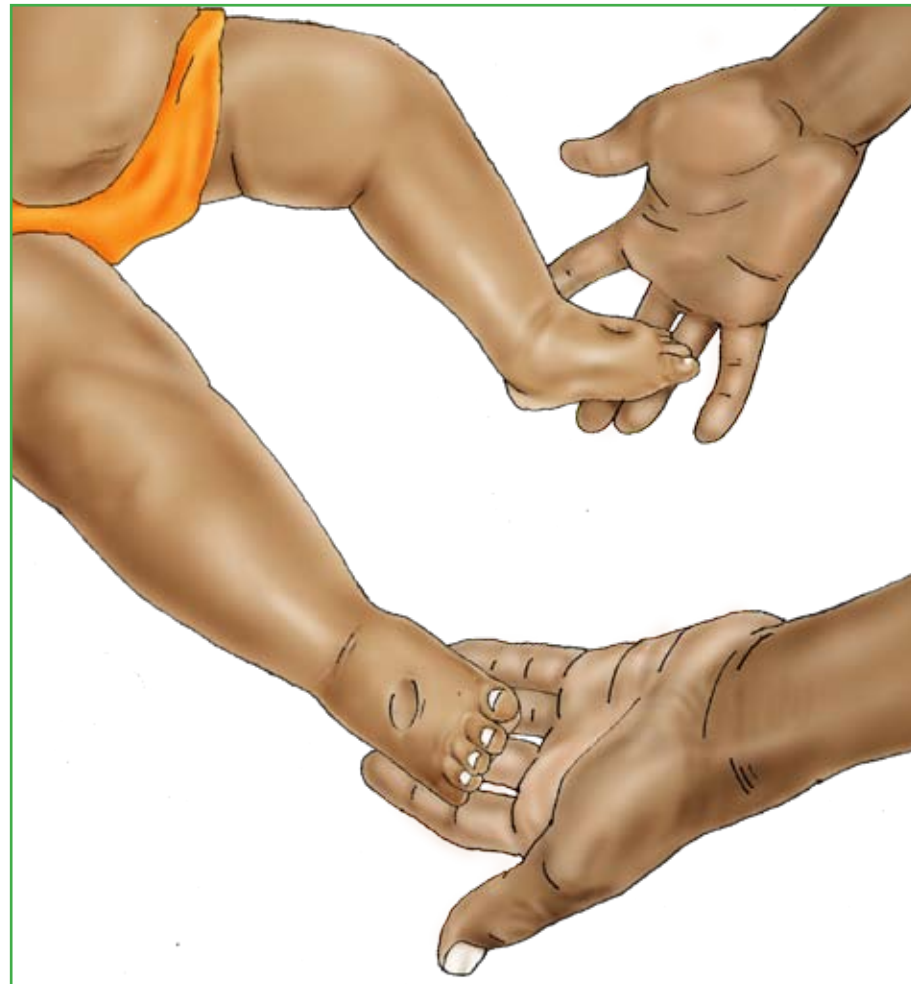

# RUTF



- RUTF stands for Ready-to-use Therapeutic Food.
- RUTF is specially made to treat malnutrition and can only be prescribed by a health worker
- RUTF should not be shared
- The client should eat and complete the daily prescribed amount of RUTF sachets ( packets).
- If the client develops any symptoms such as diarrhoea, vomiting, etc while on RUTF, he or she should see a health worker



# How to give RUTF to a malnourished child

(if breastfed child)  
Breastfeed your child before giving RUTF. Young children should continue to breastfeed regularly.



Use soap and clean running water to wash your child's hands before eating.



RUTF is for the malnourished child only and should not be shared. Ensure your child completes the daily dose of RUTF as instructed by the health worker



Always offer plenty of clean water (or breast milk) while eating RUTF. RUTF makes your child thirsty and your child will have to drink more than usual.



# How should a Malnourished Adult take RUTF



↑ Use soap and clean running water to wash your hands before eating.



↑ RUTF is for you only and should not be shared. Ensure that you complete the daily dose of RUTF as instructed by the health worker



↑ Always drink plenty of clean water while eating RUTF. RUTF makes you thirsty and you will have to drink more than usual.

# How to Protect, Store and Safely Dispose of Empty RUTF Sachets

The RUTF packet should be rolled after every use and remaining RUTF in the packet should be put in sealed plastic bag until next dosing.

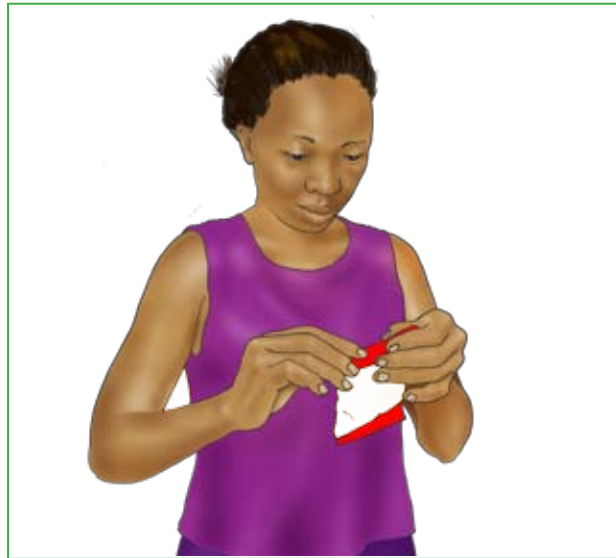

The RUTF sachet should be put out of reach of people, rodents, insects and sun. You can keep RUTF in a covered basket hanging on the beams of the roof, a covered pot or bucket or in a closed cupboard.



Always dispose of the empty packets of RUTF safely, either by putting them in a latrine or by burning them.

# Home-visit follow-up guide

ASK	DO
	Be sure to bring your bag with counselling cards and other necessary job aids. Greet the client.
1	
2	Check (and ask) for any signs requiring referral.
3	
4	
<b>For clients receiving RUTF</b>	
5	Give advice on how to cope with the problem(s).
6	Compare cards with the client's information, calculate how many full sachets should be remaining.
7	Check whether stored properly. Check whether the number remaining is appropriate. If not, find out what happened. Give hands-on advice on how to improve.
8	Check whether disposed properly.
9	Check for: <ul style="list-style-type: none"> <li>➤ if breastfed child: breastfeed first</li> <li>➤ hand washing</li> <li>➤ like/dislike</li> <li>➤ drinking potable water</li> </ul> If any of these actions were poor, find out why and stress the importance of the points above. Give hands-on advice on how to improve.
<b>For all clients</b>	
10	<p>What did you agree to practise with the health worker (e.g. hygiene, diet)?</p> <ul style="list-style-type: none"> <li>➤ Have you tried the agreed practice?</li> <li>➤ What happened when you tried the new practice?</li> <li>➤ What difficulties did your face trying the practice and how did you solve them?</li> <li>➤ Do you like the practice? Will you continue the practice?</li> </ul> <p>Congratulate the client for trying the new practice.</p> <p>Praise the client and motivate him or her to continue the practice.</p>
11	<p>During my last visit, what did we agree you would practise (e.g. hygiene, diet)?</p> <ul style="list-style-type: none"> <li>➤ Have you tried the agreed practice?</li> <li>➤ What happened when you tried the new practice?</li> <li>➤ What difficulties did your face trying the practice and how did you solve them?</li> <li>➤ Do you like the practice? Will you continue the practice?</li> </ul> <p>Congratulate the client for trying the new practice.</p> <p>Praise the client and motivate him or her to continue the practice.</p>
12	<p>Is there any new issue that has come up lately? If yes, probe which ones.</p> <p>Counsel on these issues.</p> <p>If no issues came up, counsel on other relevant behaviors. Ensure to address the behaviors suggested by the health worker on the referral card.</p> <p>If possible, use counselling cards. Reach-an-agreement on a new practice and encourage to try the new practice.</p>
13	Are there any other questions? Can I help you with anything else?
14	Ensure to remind the date. Also agree on a date for your next visit.
15	Thank the client for his or her time.
16	Update notes and data on the client.

# Home-visit follow-up guide

## For Moderately Malnourished Adults on RUTAFABlend

	ASK	DO
		Be sure to bring your bag with counselling cards and other necessary job aids.
1		Greet the client.
2	How are you feeling today ?	Check (and ask) for any signs requiring referral.
3	How have you been feeling since your last visit? When did you last see a health worker? What did you discuss?	
4	Are you still on RUTAFABlend / Have you received RUTAFABlend?	
<b>For clients receiving RUTAFABlend</b>		
5	How have you been feeling since you started taking RUTAFABlend?	Give advice on how to cope with the problem(s).
6	Please show me your referral card and OTC ration card?	Compare cards with the client's information, calculate how many full sachets should be remaining.
7	Can you please tell me the number of remaining packets of RUTAFABlend?	Check whether stored properly. Check whether the number remaining is appropriate. If not, find out what happened. Give hands-on advice on how to improve.
8	Where do you dispose of the empty packets?	Check whether disposed properly.
9	Can you tell me how you prepare RUTAFABlend?	Check for: ➤ hand washing ➤ like/dislike ➤ drinking potable water If any of these actions were poor, find out why and stress the importance of the points above. Give hands-on advice on how to improve.
<b>For all clients</b>		
10	What did you agree to practise with the health worker (e.g. hygiene, diet)? ➤ Have you tried the agreed practice? ➤ What happened when you tried the new practice? ➤ What difficulties did your face trying the practice and how did you solve them? ➤ Do you like the practice? Will you continue the practice?	Congratulate the client for trying the new practice.  Praise the client and motivate him or her to continue the practice.
11	During my last visit, what did we agree you would practise (e.g. hygiene, diet)? ➤ Have you tried the agreed practice? ➤ What happened when you tried the new practice? ➤ What difficulties did your face trying the practice and how did you solve them? ➤ Do you like the practice? Will you continue the practice?	Congratulate the client for trying the new practice.  Praise the client and motivate him or her to continue the practice.
12	Is there any new issue that has come up lately? If yes, probe which ones.	Counsel on these issues. If no issues came up, counsel on other relevant behaviors. Ensure to address the behaviors suggested by the health worker on the referral card. If possible, use counselling cards. Reach-an-agreement on a new practice and encourage to try the new practice.
13	Are there any other questions? Can I help you with anything else?	
14	When is your next visit to the health centre planned for?	Ensure to remind the date. Also agree on a date for your next visit.
15		Thank the client for his or her time.
16		Update notes and data on the client.

# What is RUTAFABA Blend



- RUTAFABA is a partially cooked food.
- RUTAFABA is specially made to treat malnutrition and can only be prescribed by a health worker.
- RUTAFABA should not be shared.
- The client should eat and complete the daily prescribed amount of RUTAFABA.
- The client or a caregiver needs to cook RUTAFABA using clean potable water and cooking fuel.
- Other foods e.g lemon, tamarind may be added to make it taste better.
- If the client develops any symptoms, such as •  
diarrhea, vomiting, etc. while on RUTAFABA, he or she should see a health worker.

# How to Prepare RUTAFA Blend

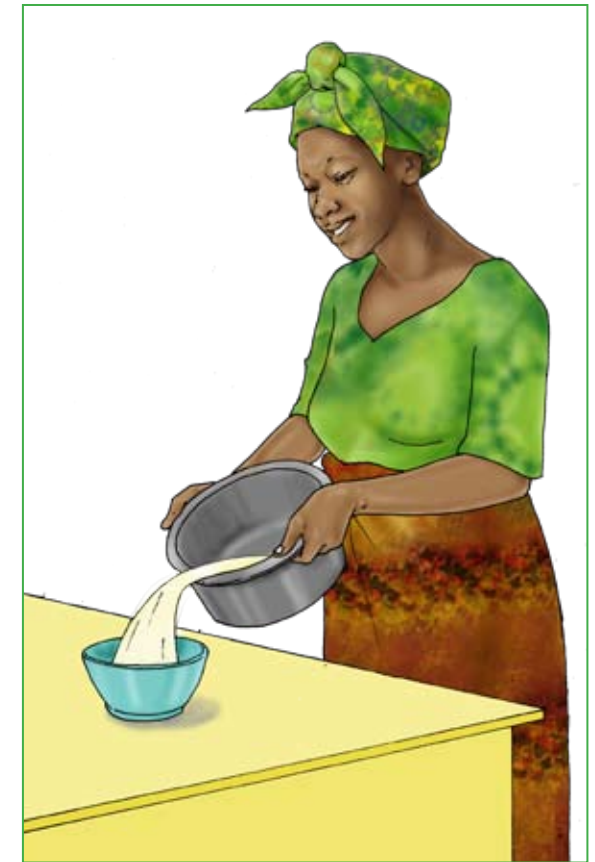

For one meal of RUTAFA blend, Mix half a sachet of RUTAFA Blend with a half litre / 1 “Nice” cup (or 500ml mineral water bottle) of warm drinking water.



Boil for 15 minutes and stir continuously. Add more clean portable / dinking water if porridge is too thick.



You can add lemon, tamarind (include other examples) to the cooked porridge to improve taste if you would like.



Use soap and clean running water to wash your hands before preparation of RUTAFA blend and before eating.

# How to Take RUTAFA Blend



Use soap and clean running water to wash your hands before eating RUTAFA blend.



RUTAFA blend is a special nutritional treatment only for you and should not be shared. Eat the full daily dose of one sachet every day.



Take half a sachet in the morning

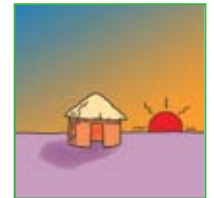

And half a sachet in the evening to complete the full sachet.

# How to Store RUTAFABA Blend

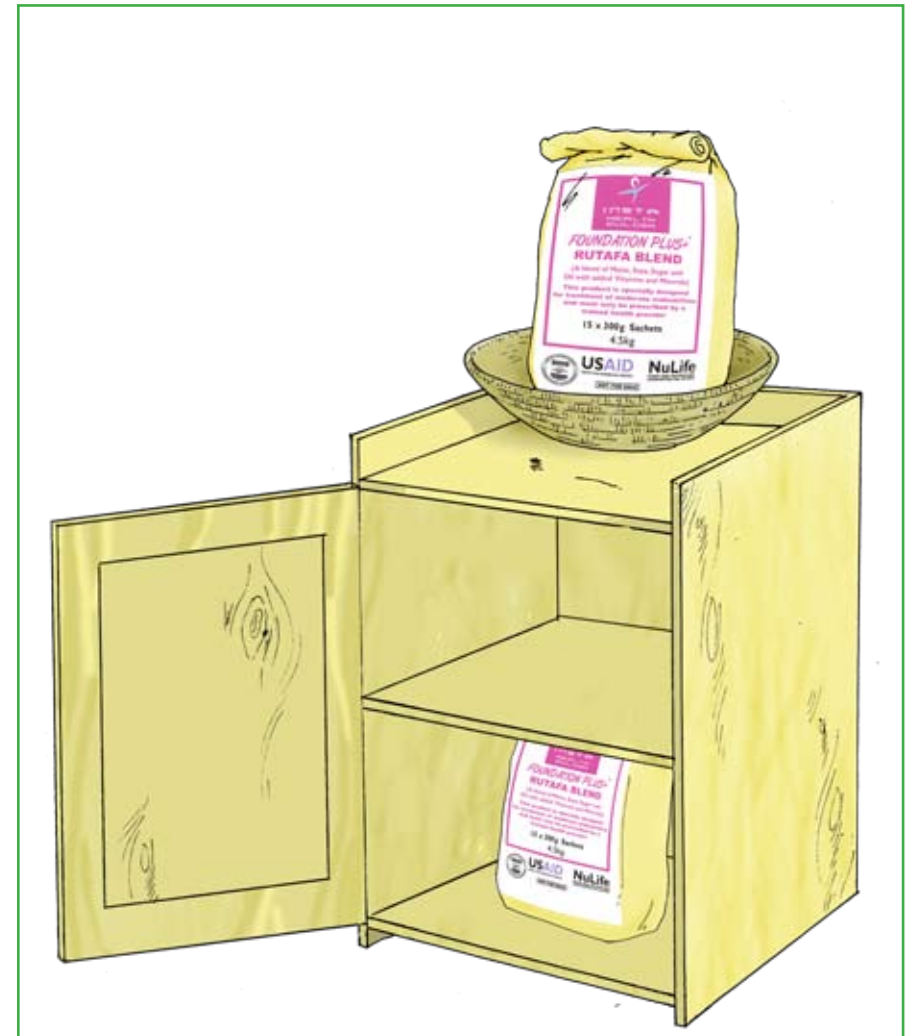

The sachets of RUTAFABA blend should be kept in a dry place and put out of reach of people, rodents, insects and sun. You can keep RUTAFABA Blend in a covered basket raised above the ground or in a closed cupboard.